

Truss Repair and Modifications

Overview

Revised 4/7/2017

SBCA

SBCA has been the voice of the structural building components industry since 1983, providing educational programs and technical information, disseminating industry news, and facilitating networking opportunities for manufacturers of roof trusses, wall panels and floor trusses. **SBCA** endeavors to expand component manufacturers' market share and enhance the professionalism of the component manufacturing industry.

Copyright © 2017 Structural Building Components Association.

Introduction

- Trusses are typically designed for a specific application.
- Therefore, truss repairs or modifications must be analyzed on a case by case basis.
- The repair designer needs to be provided with accurate information.
 - In simple scenarios, a “marked-up” Truss Design Drawing (TDD) or photos of the damaged truss may be sufficient.
 - In more complex situations, a jobsite visit may be required.

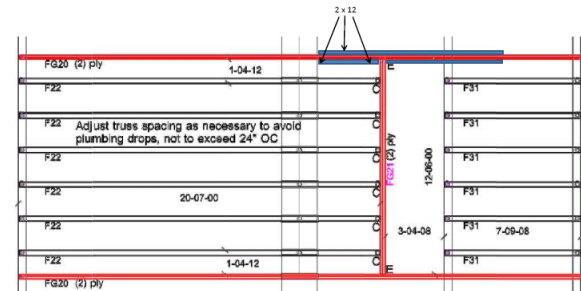
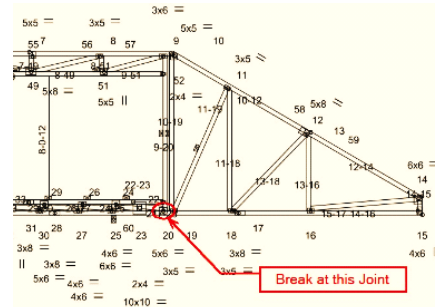

Introduction

- What is the difference between a Repair and a Modification?
 - **Truss Repair (top):** restoring a truss back to its original shape and strength in situations where damage has caused a change or a reduction in either.
 - **Truss Modification (bottom):** altering a truss profile, loading, and/or bearing conditions to fit a situation for which the original truss was not designed.

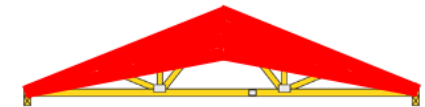
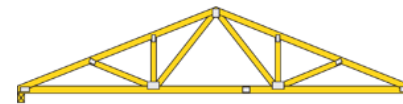
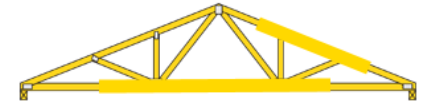
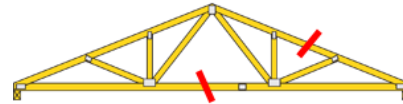

Introduction

- The truss repair or modification must result in a truss that is able to safely carry all intended loads.
- **Depending on the extent of damage, some trusses cannot be repaired and must be replaced.**
- This presentation will cover the fundamental principles behind truss repair, as well as steps for a successful truss repair.

Key Definitions

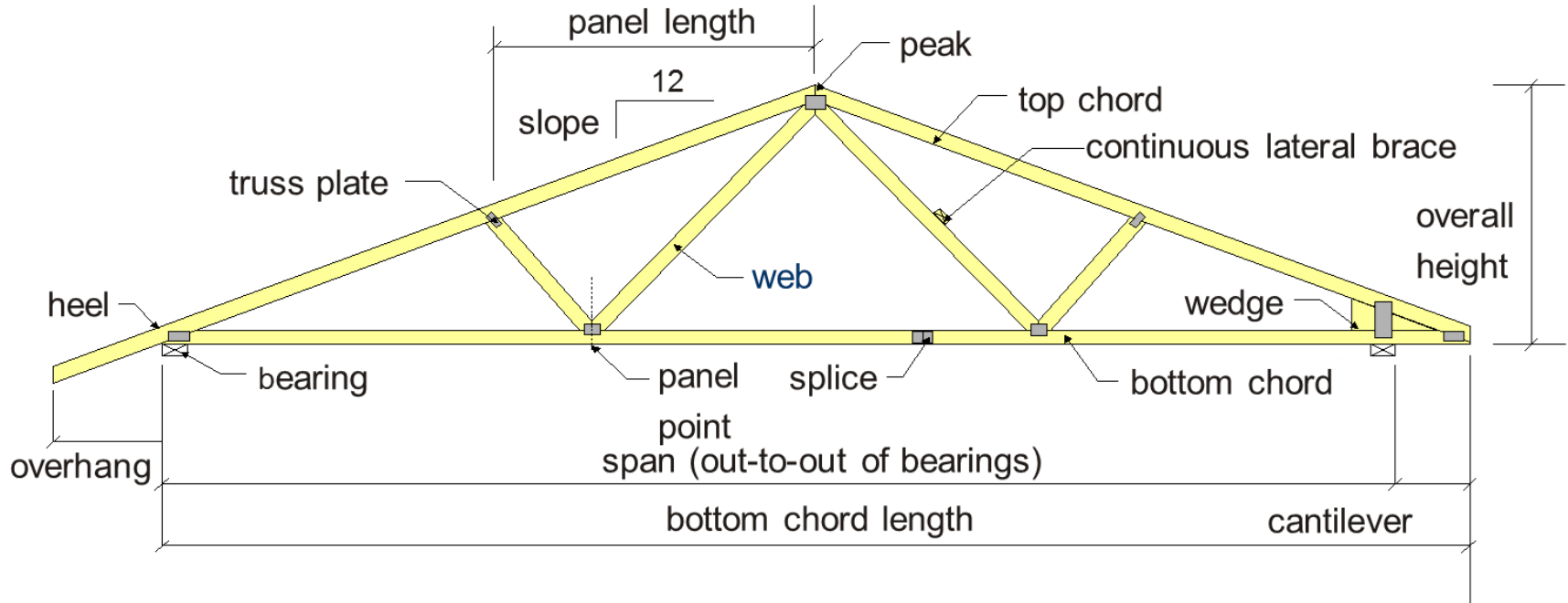

Key Definitions

- Further definitions specific to truss repairs

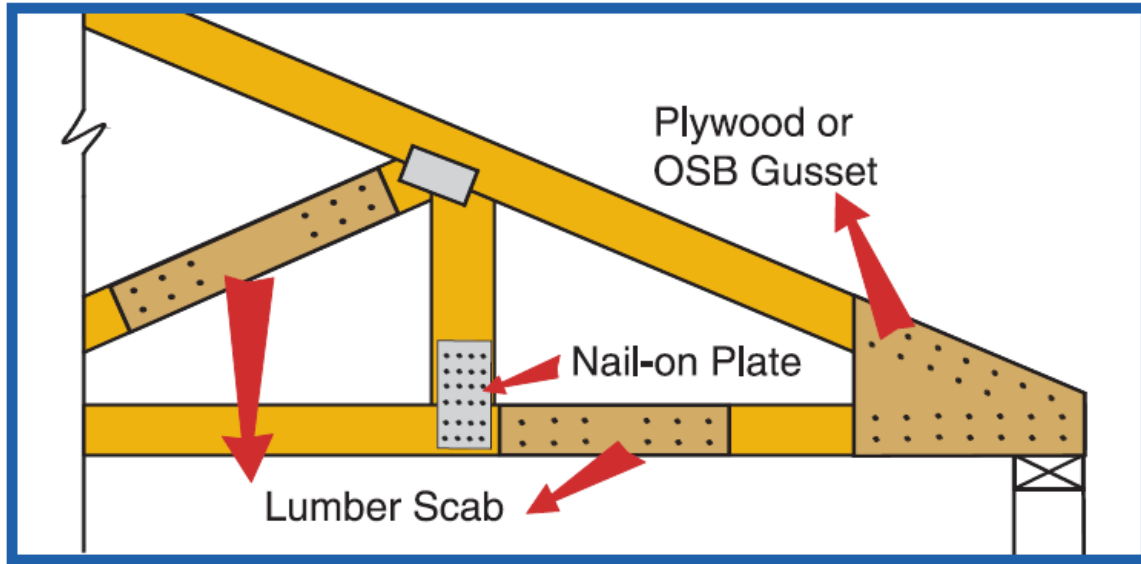

Key Definitions

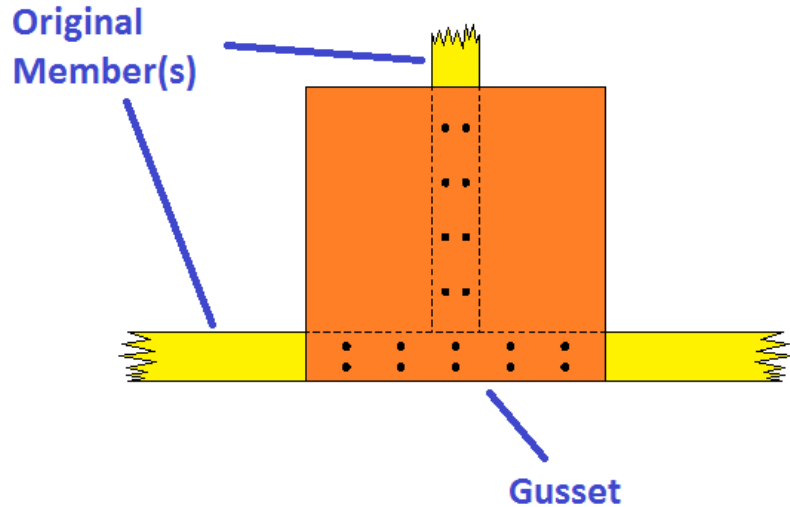

Gusset repair (OSB/Plywood)

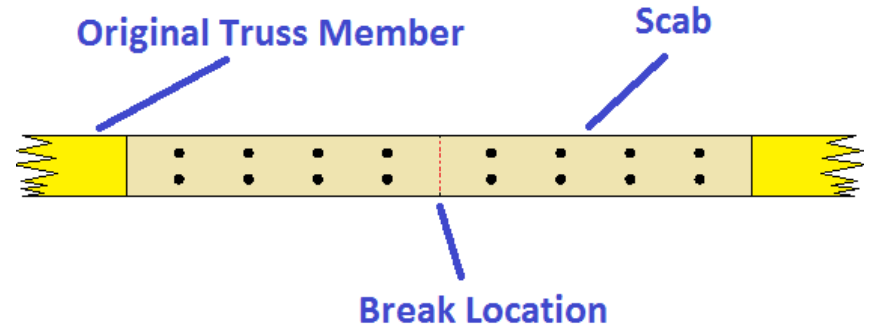

Scab repair (lumber/engineered wood)

Design Concepts

- Load vs. Resistance
- Externally applied loads become internal forces

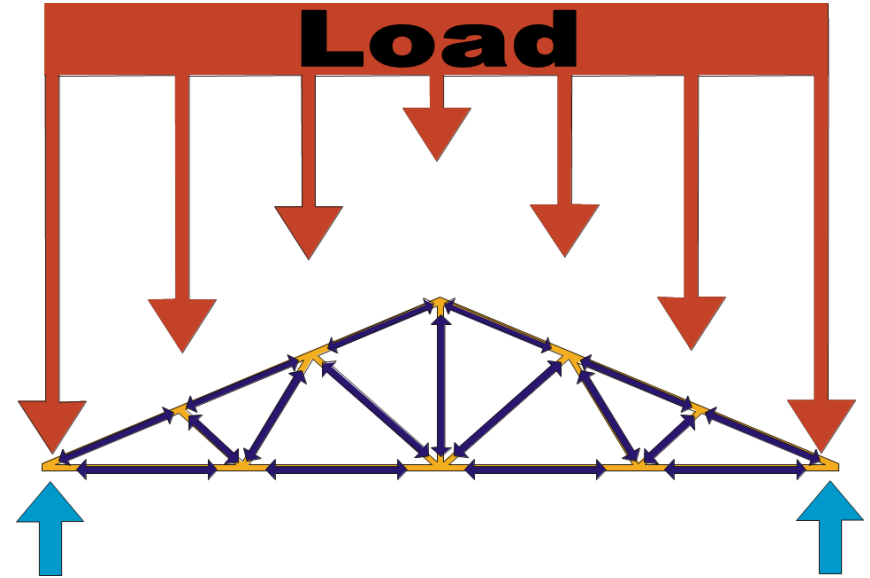

Design Concepts

- Axial Forces:
 - Axial forces act parallel to the member
 - There are two types of axial forces:
 - *Tension* forces pull on each truss member
 - *Compression* forces push on each truss member
 - These forces are developed through the resistance of the truss members to gravity, wind, and other design loads.

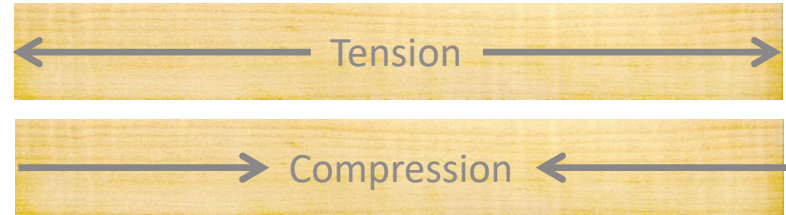

Design Concepts

- Shear Forces:
 - Act perpendicular to a member's longitudinal direction.
 - Shear force is highest at joints, concentrated load locations, and bearing locations.

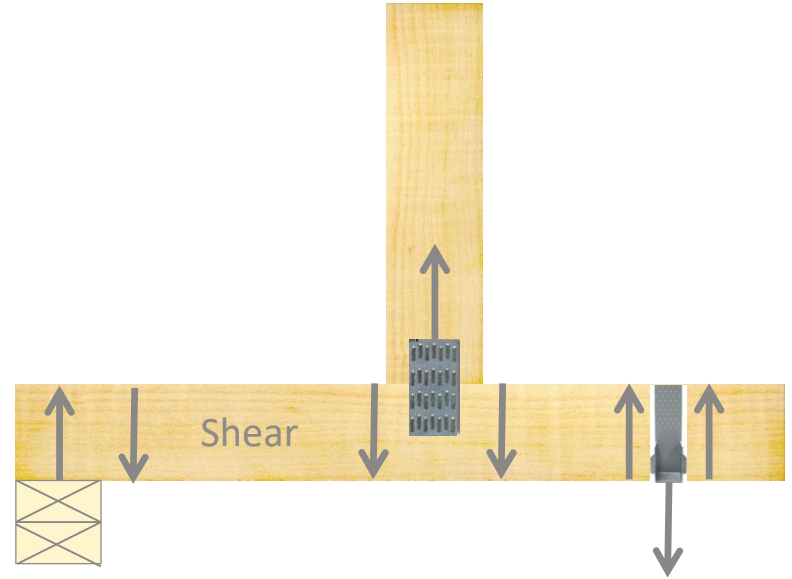

Design Concepts

- Moment Forces:
 - Cause rotation
 - Depending on the fixities of the joints, can occur in chords and sometimes in the webs.
 - Are highest in heels, peak, pitch-breaks, and chord joints where large axial forces come together either at different angles and/or in opposing directions (tension versus compression).
 - In some cases, the moment acting on the joint will be greater than any of the axial forces
 - This will not necessarily show up on the design drawing, but will be accounted for in the design of the gusset plate.

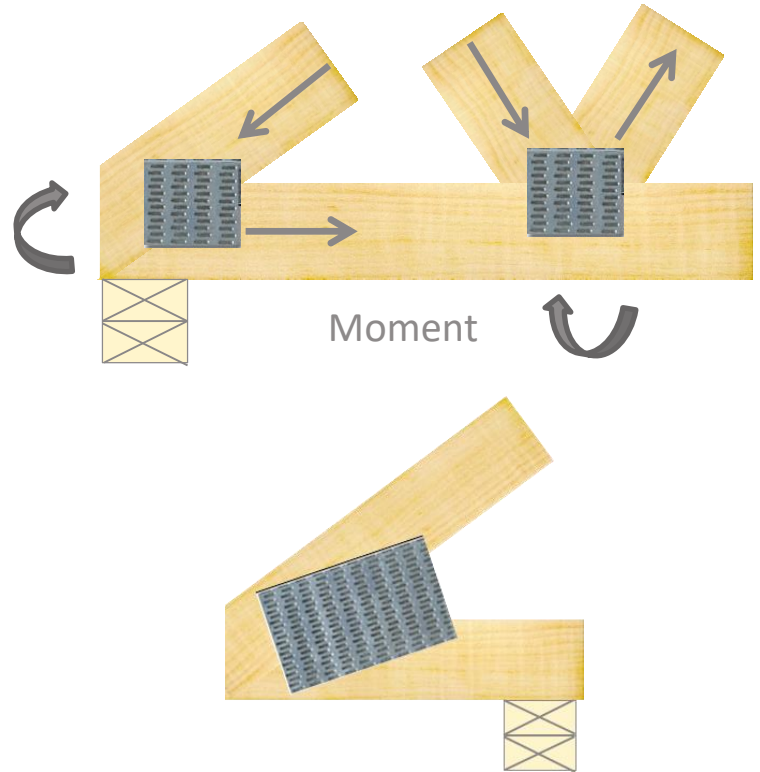

Reasons for Repairs

- Damage occurring during the construction process:
 - Manufacturing errors
 - Storage, handling, and installation errors
 - Jobsite modifications
 - Overloading
- Design, construction, and serviceability problems

Reasons for Repairs – Manufacturing Errors

- Incorrect, loose, missing, or mis-installed connector plates
- Poorly constructed joints
- Incorrect lumber



Reasons for Repairs – Storage, Handling, and Installation

- Rigging and hoisting mistakes
- Lack of protection from the elements



Reasons for Repairs – Storage, Handling, and Installation

- Plate and lumber damage can result from improper handling

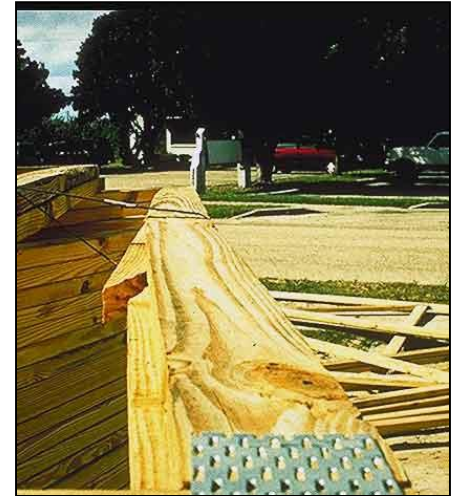

Reasons for Repairs – Storage, Handling, and Installation

- Insufficient restraint and bracing



Reasons for Repairs – Storage, Handling, and Installation

- Check truss orientations before installing
- This is especially important for unevenly loaded girders

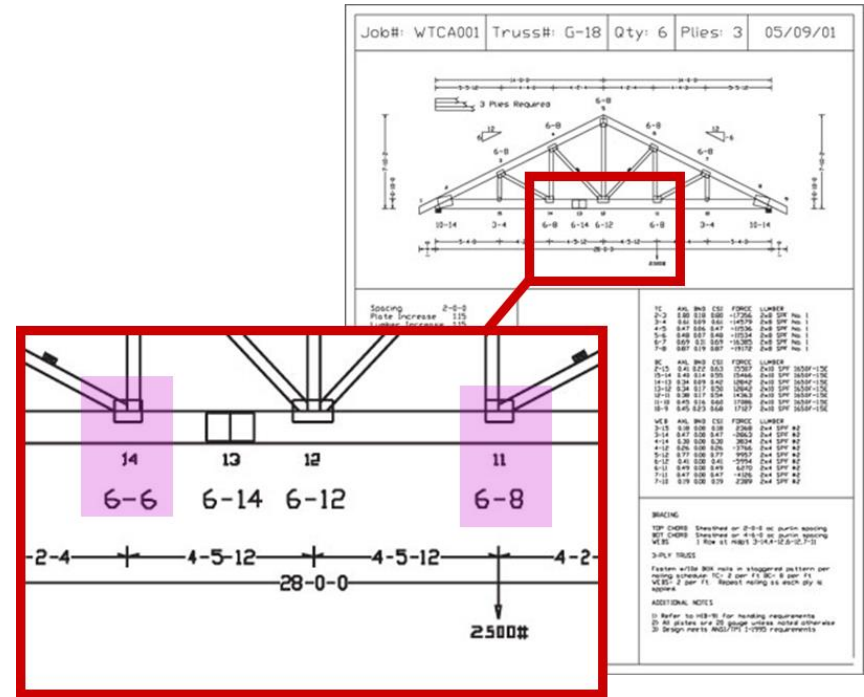

Reasons for Repairs – Storage, Handling, and Installation

- Be sure to check both left-to-right and upside down orientations

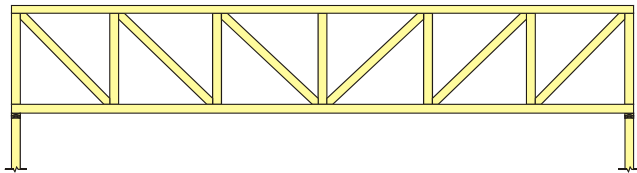
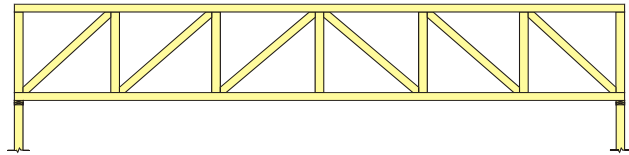

Truss "A" is installed "backwards" and "upside down."

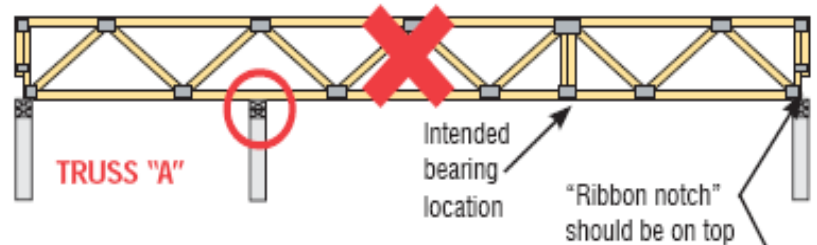

Truss "B" is installed correctly.

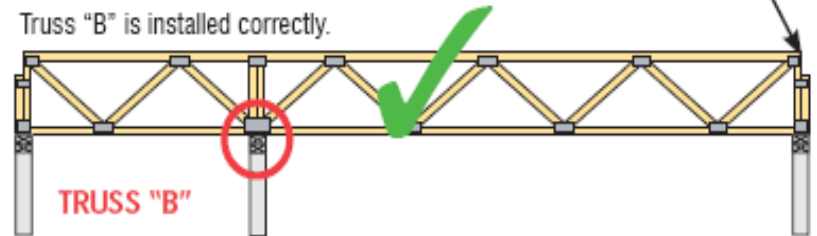

Reasons for Repairs – Storage, Handling, and Installation

- Check bearing locations
- Are supports in the correct locations?



Reasons for Repairs – Jobsite Modifications

- Cutting webs or chords to accommodate mechanical equipment (or for any reason) requires a repair



Reasons for Repairs – Jobsite Modifications

- Holes may compromise the strength of the lumber, even if each individual hole is small.



Reasons for Repairs – Overloading

- Construction materials are often loaded onto roofs, which can cause damage
- Loading materials at the ridge is particularly problematic



Reasons for Repairs – Overloading

- Even smaller pieces of scrap material can be significant in large quantities



Reasons for Repairs – Overloading

- A repair should be made if loads are added for which the truss was not designed.
- This building was not originally designed as a butcher shop and the trusses were not designed for the loads required



Repairing Damaged Trusses – IBC/IRC

- IBC 2303.4.5 / IRC R502.11.3 & R802.10.4
- **Alterations to trusses.**

Truss members and components shall not be cut, notched, drilled, spliced or otherwise altered in any way without written concurrence and approval of a registered design professional. Alterations resulting in the addition of loads to any member (e.g., HVAC equipment, piping, additional roofing or insulation, etc.) shall not be permitted without verification that the truss is capable of supporting such additional loading.

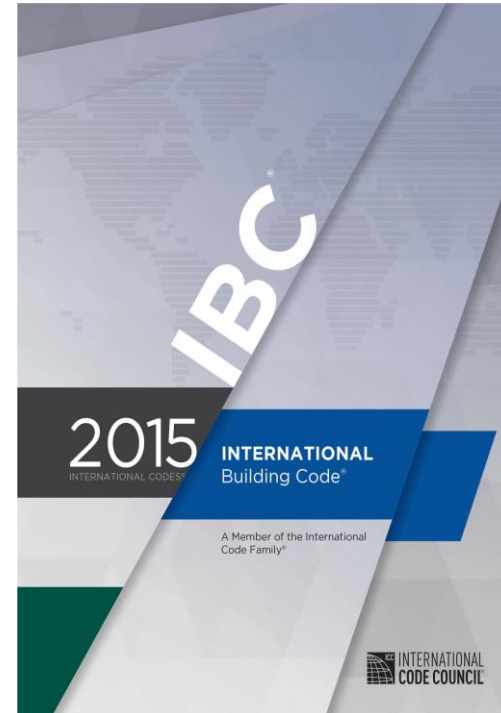

Repairing Damaged Trusses – ANSI/TPI 1

- ANSI/TPI 1 2.3.4 – Requirements of the Contractor
- **Pre- and Post-Installation Check**
The contractor shall examine the trusses delivered to the jobsite and examine the trusses after they are erected and installed for:
 - a. Dislodged or missing connectors,
 - b. Cracked, dislodged or broken members, and
 - c. Any other damage that may impair the structural integrity of the truss.

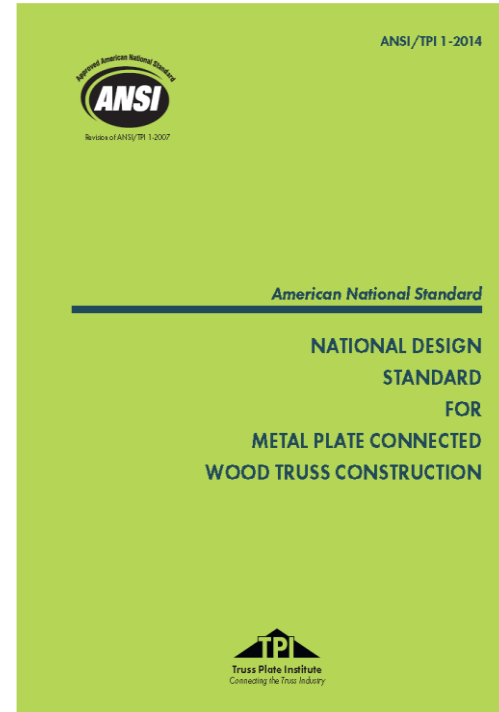

Repairing Damaged Trusses – ANSI/TPI 1

- ANSI/TPI 1 2.3.4 – Requirements of the Contractor
- **Truss Damage Discovery**

In the event that damage to a truss is discovered that would likely impair the structural integrity of the truss , the contractor shall:

 - a. Ensure the truss is not erected, or
 - b. If the truss has already been erected, properly shore and support the truss to prevent further damage from occurring and keep the truss free of any load until field repairs have been properly completed.

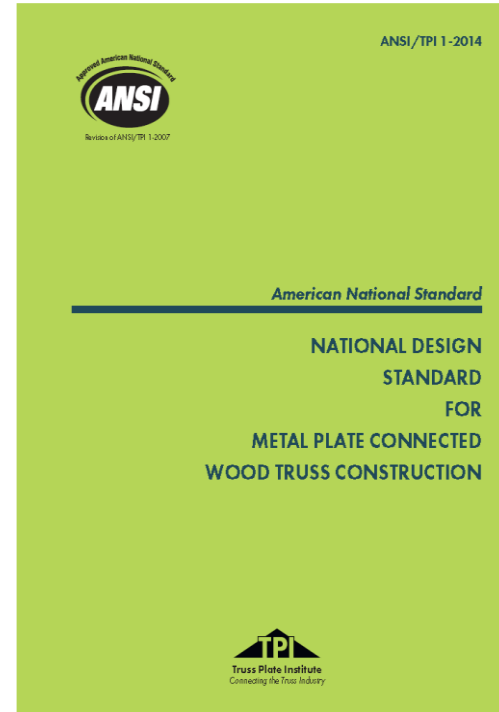

Repairing Damaged Trusses – ANSI/TPI 1

- ANSI/TPI 1 2.3.4 – Requirements of the Contractor
- **Truss Damage Responsibility**
In the event of damage the contractor shall:
 - a. Contact the truss manufacturer and building designer to determine an adequate repair, and
 - b. Construct the repair in accordance with the written instructions and details provided by the truss manufacturer, building designer and/or any registered design professional.

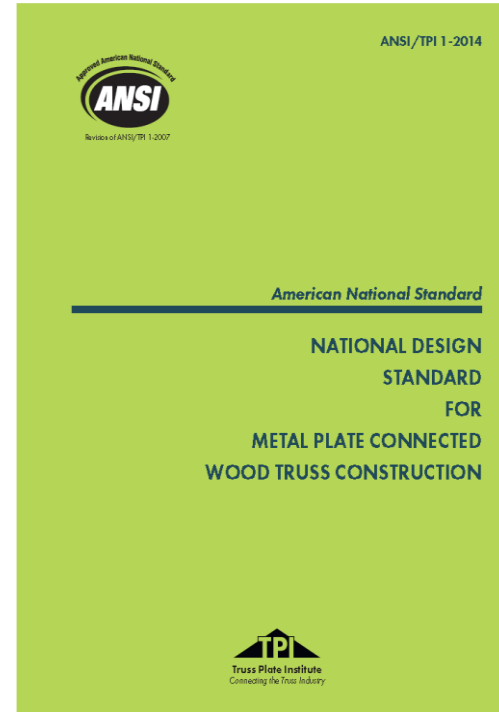

Repairing Damaged Trusses – BCSI

- BCSI-B5 recommends the following steps to correct damage, jobsite modifications or installation errors:
 1. Temporarily brace or support the truss to prevent further damage to the truss and danger to the workers.
 2. Report damage, alterations or installation errors to the truss manufacturer immediately. Provide the following information, if possible:
 - Job name and/or number
 - Truss ID mark
 - Location of the truss on the Truss Placement Diagram, as applicable
 - Is the truss already installed?
 - Type of damage (i.e., lumber and/or connector plates)
 - If lumber (location of damage, dimension of damage, description of damage)
 - If connector plates (Location of damage, joint number(s), size of plates, description of damage)
 - If possible it is best to “mark-up” the TDD of the truss(es) that are damaged.
 - Photographs are also helpful.

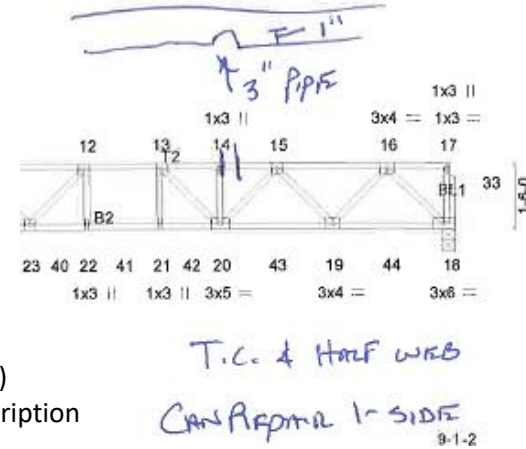

Repairing Damaged Trusses – BCSI

3. DO NOT repair without a Truss Repair Design Drawing (TRDD)
 - Repairing a truss prior to receiving a TRDD could result in additional cost or an unreparable condition.
 - DO NOT install a broken or damaged truss until a repair has been made.



Repairing Damaged Trusses – BCSI

4. Prior to beginning the repair, lay the truss flat on a solid, level surface.
 - If the truss is already installed, shore up the truss to relieve any load.
5. Repair the truss by following the information provided in the TRDD exactly. Make sure to use the correct materials as specified.
 - Seek professional guidance if anything is unclear.
 - Lumber and fasteners are not created equal
 - Slight variations in loading or damage conditions can significantly affect the repair required.

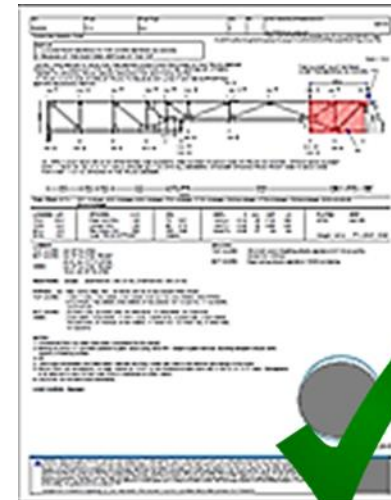
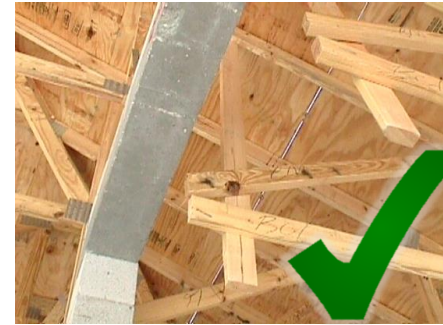

Repairing Damaged Trusses – BCSI

6. Keep the TRDD in case the building official, building designer or owner requests it.
7. If the TRDD is not for the specific condition you are repairing, do not use it. Always follow the TRDD prepared for the specific situation.
8. If the TRDD cannot be accomplished, inform the repair designer.



Common Repair Materials

- Notify the truss designer or truss manufacturer about:
 - Preferred materials or methods for the repair
 - Availability of special order materials
 - If there is a plate press on site
 - Additional considerations not listed



Common Repair Materials

OSB/Plywood

- Typically sold as 4'x8' panels
- Many thicknesses and span ratings
- Ensure that the panels specified on the truss repair design drawing are used in the repair.



Lumber

- Many species and grades available
- Typically, 2x nominal width is used for repairs
- Commonly sold in nominal depths of 3, 4, 6, 8, 10, and 12 inches and in lengths up to 20 feet



Common Repair Materials

Structural Composite Lumber

- Available in many sizes and strengths, can be custom ordered
- Available in lengths longer than 20 feet
- Often used in longer span floor truss repairs when a repair is not possible with lumber or OSB



Laminated Veneer Lumber (LVL)



Parallel Strand Lumber (PSL)



Glued Laminated Timber (Glulam)

Common Repair Materials

Portable Plate Press

- If available, a plate press may be used to replace a plate that is damaged or missing.
- Note that the tooth holding value in lumber that has had a gusset plate removed is reduced by 50%.
- Thus, the replacement plate must be sized larger than the original to allow the plate to connect into good lumber.
- The new plate may not need to be 50% bigger, but the truss designer needs to recalculate the design to ensure the plate is adequate.



Common Repair Materials

Manufactured scab truss

- Often used in situations where connection forces are high and the truss profile does not allow for a repair with typical materials.
- Designed and built at a shop and installed on site.

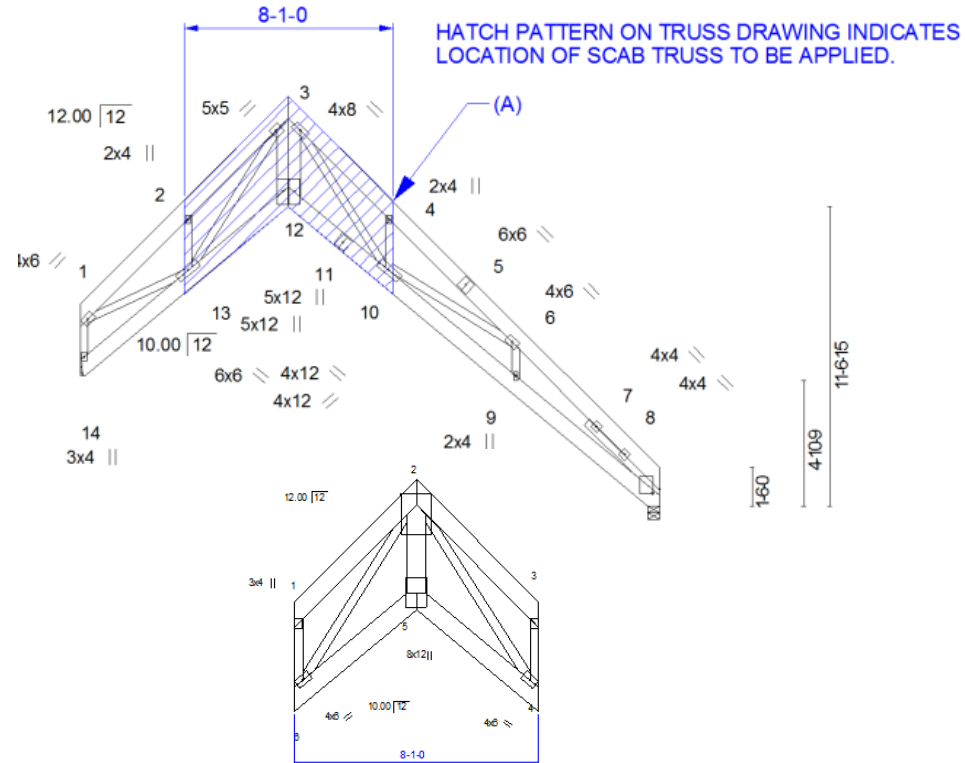

Common Repair Materials

Nails

- Available in many lengths
- Easily attached with a nail gun
- Versatile and commonly found on the job site
- Nails are less efficient in connecting wood members than metal gusset plates, but clinching, if allowed, can reduce the size of the repair

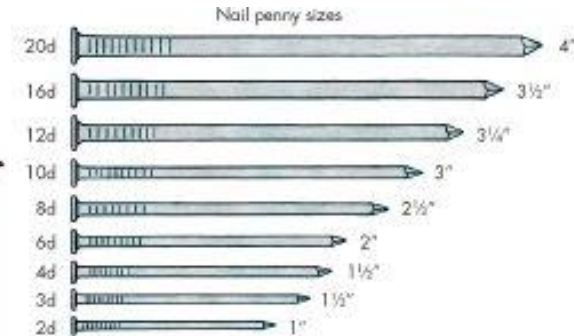

Common Repair Materials

Nails – Clinching

- NDS 11.1.6.5 allows nails to be clinched in a gusset repair.
- Clinching increases the withdrawal value of the nail by doubling the shear value of the nail.
- This allows more force to be transferred directly to the adjoining members.
- A gusset repair can be significantly smaller with clinched nails than non-clinched nails.



Common Repair Materials

Nails – Clinching

- Gussets must be installed on both sides of the repair.
- Fasteners must be of sufficient length to pass through both gussets and the main truss member while retaining a minimum of 3/8" to be clinched.
- Repairs that specify clinched nails must use clinched nails or the repair is not valid.
- Verify in the field that nails are clinched where specified on the repair detail.

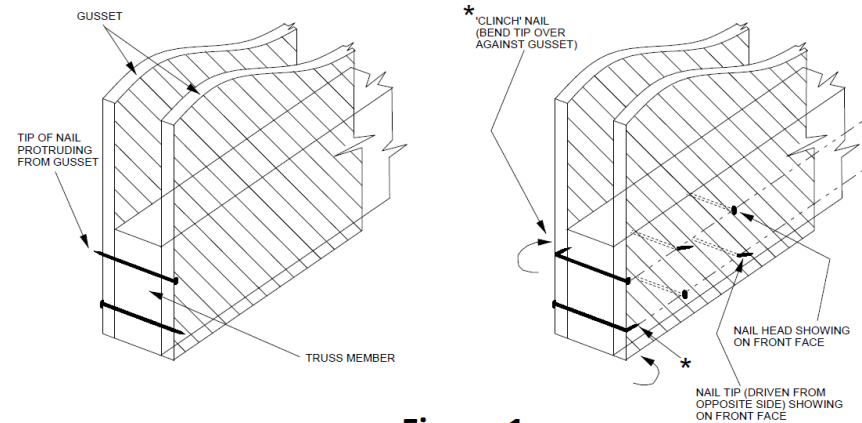
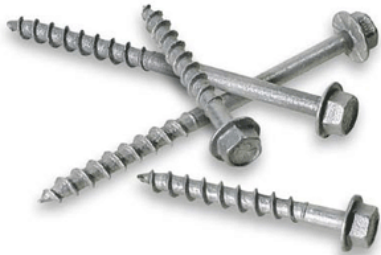

Figure 1

Common Repair Materials

Screws

- Available in many sizes and lengths
- Screws have a higher withdrawal and lateral resistance values than nails and therefore a repair can use fewer screws than nails.
- Spacing requirements may be higher than for nails
- Consult manufacturer for design values and minimum spacing requirements.



Bolts

- Machine bolts such as ASTM A307 are typically specified
- Can be used when large forces or multiple plies are involved
- Not as commonly used in truss repairs



Common Repair Materials

Adhesives

- Some adhesives create an excellent bond with the wood, providing greater strength than the wood itself.
- Application conditions must be considered including:
 - Temperature
 - Moisture
 - Surface condition of the wood member
 - Quality and supervision of labor
 - Cure time



Conclusion

- Follow the guidelines in this presentation to ensure that the repair is completed in the safest and most economical way.
- When a damage condition is discovered, notify the truss manufacturer immediately and provide complete information and photos of the damage condition.
- Follow the instructions in the repair detail completely to prevent additional damage or rework.
- Keep the repair detail and provide to the building inspector if requested.

Resources

- ANSI/AWC NDS-2012, *ASD/LRFD NDS; National Design Specification for Wood Construction*. 2012; American Wood Council, 222 Catoctin Circle, SE, Suite 201, Leesburg, VA 20175.
- American National Standard: National Design Standard for Metal Plate Connected Wood Truss Construction, ANSI/TPI 1 – 2014; Truss Plate Institute; Revision of ANSI/TPI 1 – 2007.
- BCSI Building Component Safety Information: Guide to Good Practice for Handling, Installing, Restraining & Bracing of Metal Plate Connected Wood Trusses 2013 Edition, Chapter BCSI-B5: Truss Damage, Jobsite Modifications & Installation Errors; Jointly Produced by the Structural Building Components Association and Truss Plate Institute; Updated March 2015.

Resources

Wood Materials

- NDS
- AITC
- APA-EWS
- TECO
- SCL Manufacturer
- SBCA
- TPI
- Technical Evaluation Reports

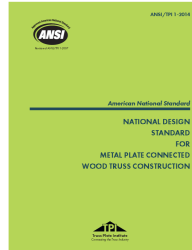
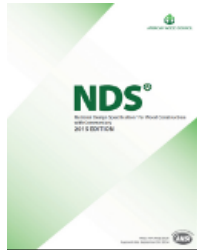

Fasteners & Connector Plates

- NDS
- Manufacturers
- AISC
- Technical Evaluation Reports
- TPI

