

# Sprinkler Loads on Trusses

Overview

Revised 3/21/2017

**SBCA**

**SBCA** has been the voice of the structural building components industry since 1983, providing educational programs and technical information, disseminating industry news, and facilitating networking opportunities for manufacturers of roof trusses, wall panels and floor trusses. **SBCA** endeavors to expand component manufacturers' market share and enhance the professionalism of the component manufacturing industry.

Copyright © 2017 Structural Building Components Association.

# Introduction

- This presentation is offered as a guide to industry standards for applying sprinkler loading, and applies to both roof and floor trusses.
- The guidelines provided in this presentation are not intended to exclude alternative solutions for specific projects that have been designed by a qualified Registered Design Professional.
- Specific designs should be confirmed with the local building authorities.

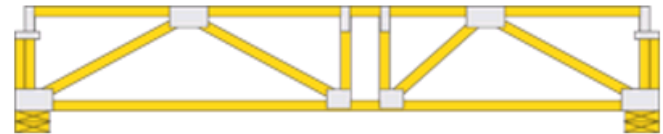
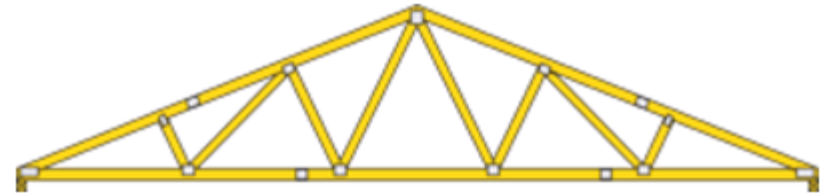

# Introduction

- Building Designers need to specify dead and live loads of both fire sprinkler systems and other load requirements imposed under the model building codes.
- Truss Designers are responsible for incorporating the additional load from the fire sprinkler systems into the truss design.

# Key Definitions

- **Builder Designer (ANSI/TPI 1 Section 2.2)**
  - The owner of the building or the person that contracts with the owner for the design of the framing structural system and/or who is responsible for the preparation of the construction documents. When mandated by the legal requirements, the Building Designer shall be a registered design professional.
- **Dead Load (IBC Section 202)**
  - The weight of materials of construction incorporated into the building, including but not limited to walls, floors, roofs, ceilings, stairways, built-in partitions, finishes, cladding and other similarly incorporated architectural and structural items, and the weight of fixed service equipment, such as cranes, plumbing stacks and risers, electrical feeders, heating, ventilating and air-conditioning systems and automatic sprinkler systems.
- **Live Load (IBC Section 202)**
  - A load produced by the use and occupancy of the building or other structure that does not include construction or environmental loads such as wind load, snow load, rain load, earthquake load, flood load or dead load.
- **Fire Sprinkler System**
  - A system of pipes and accessories that distribute and discharge water to protect a structure and its occupants from damage or injury due to fire. In a truss system, the pipes are usually supported by the truss top chords, although sometimes they may be suspended from the bottom chord.

# Key Definitions

- Panel (Figure 1)
- Panel Length (Figures 1 & 2)
- Panel Point (Figures 1 & 2)

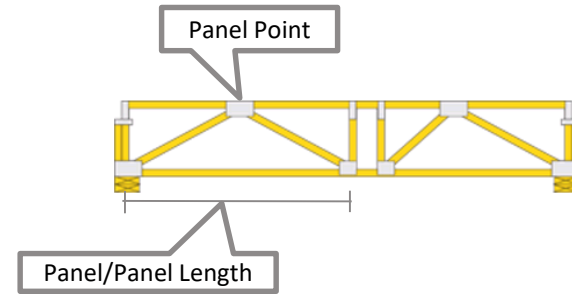

Figure 1

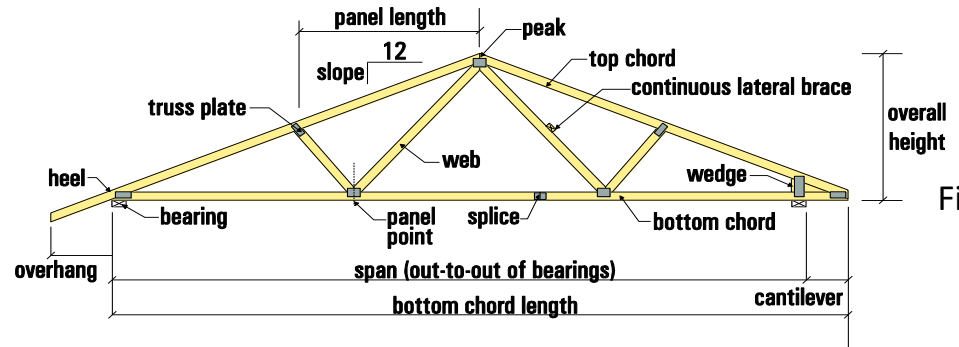

Figure 2

# Key Definitions

- Registered Design Professional (RDP): (IBC Section 202)
  - An individual who is registered or licensed to practice their respective design profession as defined by the statutory requirements of the professional registration laws of the state or jurisdiction in which the project is to be constructed.
- Truss Designer (ANSI/TPI 1 Section 2.2)
  - The person responsible for the preparation of the truss design drawings.
- Truss Manufacturer (ANSI/TPI 1 Section 2.2)
  - An individual or organization engaged in the manufacturing of trusses.

# Background

- Automatic fire sprinkler systems provide protection to a building and its contents from damage due to fire, and protection from injury of the occupants.
- When used with truss systems, they must be designed correctly to carry the additional dead load and required live loads.





# Background

- The Building Designer needs to provide the Truss Designer with the loading imposed by the sprinkler system
- This allows the Truss Designer to make provisions in the truss design for the structural effects of the fire sprinkler systems.

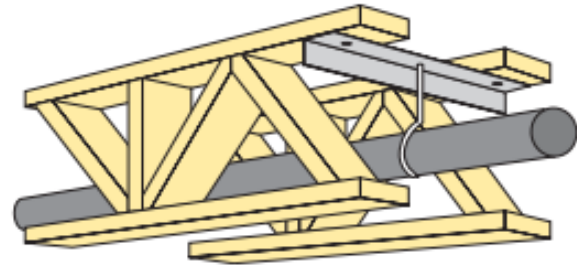
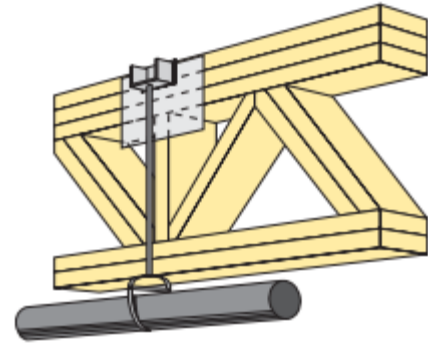

# Background

- Open webbing makes trusses highly compatible with other building trades.
  - Water lines for sprinkler systems can be run through the open webbing.
  - Trusses can easily be designed to accommodate concentrated loads imposed by sprinkler systems.

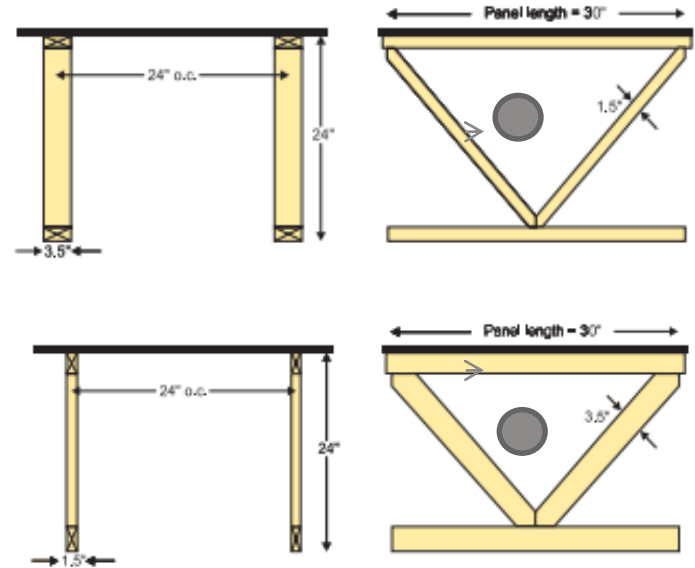

# Loading

- Loads to be accounted for include:
  - Uniform dead load of the fire sprinkler system.
  - Any concentrated dead loads not covered by the uniform load.
- The fire sprinkler system can be supported from either the top chord or the bottom chord of the truss.



# Loading

- In addition to the dead load of the water-filled pipe, the trusses should be designed for a 250-lb concentrated live load
- This is applied to any single fire sprinkler support point, but not simultaneously to all support points.
- The 250-lb. live load need not be considered simultaneously with other live loads (i.e., roof, snow, wind, etc.).

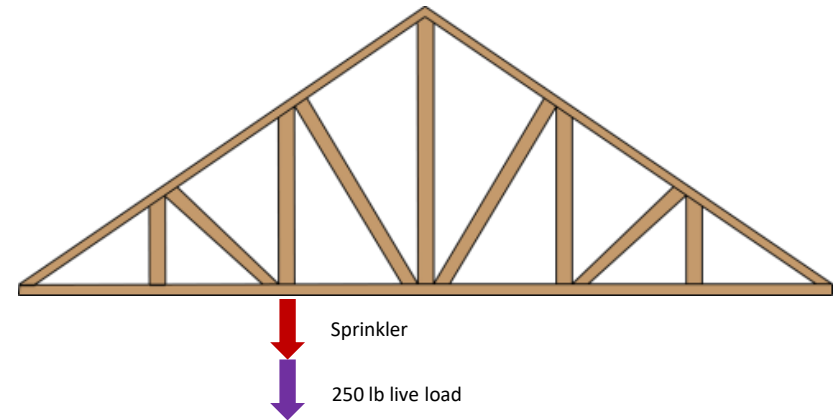

# Loading

- The intent of the 250-lb live load provision is to accommodate the weight of sprinkler installation personnel for a very short time during installation
- If multiple sprinkler lines are attached to the same truss, the 250-lb load should be applied at only one location at a time, representing only one worker per truss

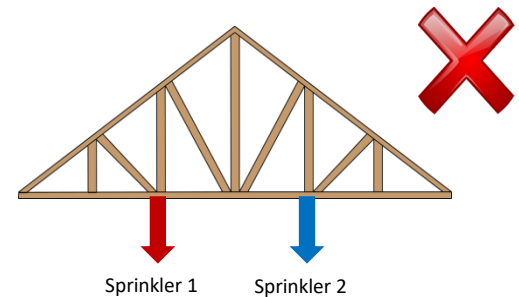
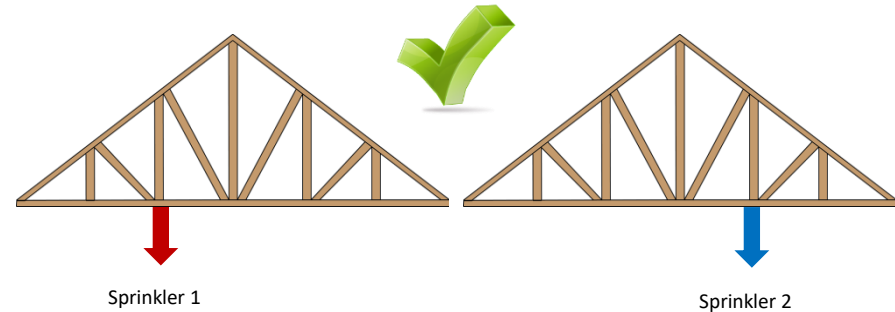

# Loading

- In residential sprinkler system installations:
  - NFPA 13D assumes that the sprinkler system will use the domestic water delivery system.
    - Additional dead loads may not need to be accounted for.
  - The truss design and fire sprinkler system design still need to be coordinated to prevent conflicts

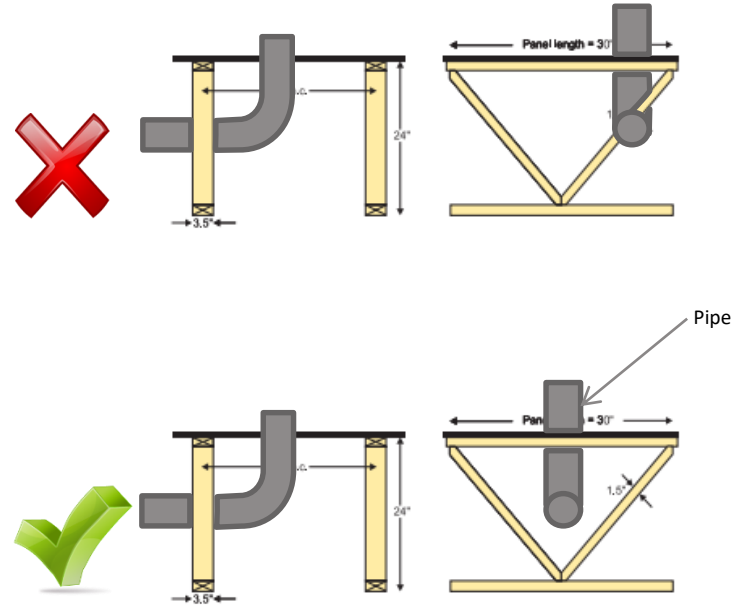

# Structural Considerations

- Trusses are capable of supporting significantly higher loads at panel points than in the spaces between the panel points.
- Location of the pipe support in relation to the truss panel points should be included in the analysis.

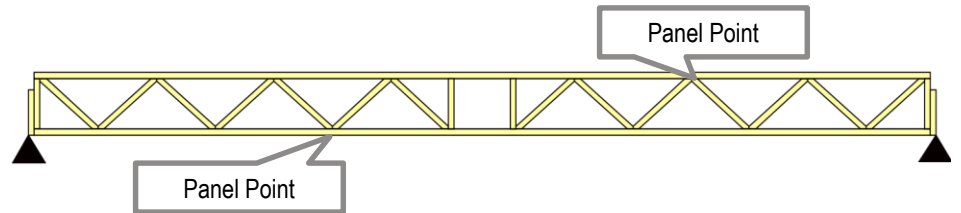
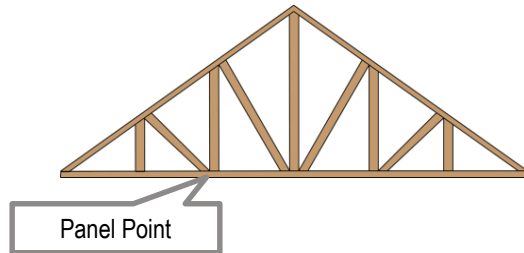

# Installation Considerations

- Large diameter pipe lines (4" or greater), and significant risers and lines running parallel to trusses may require special design provisions and/or additional members.
- Pilot holes are required for all screws.

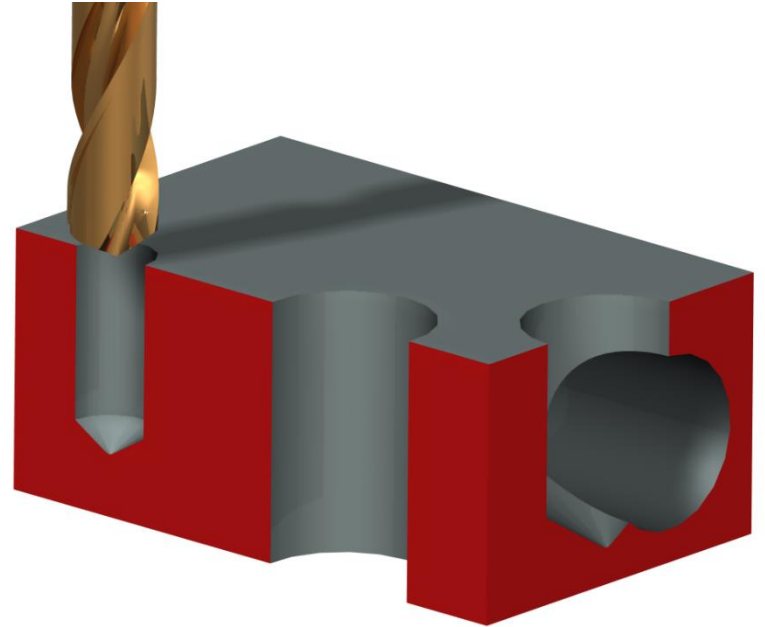



# Installation Considerations

- Locating supports within truss panels containing chord splices should be avoided.
- Connections shall be sized in accordance with *NFPA 13* or the applicable NFPA standard and *NDS* or an approved design.

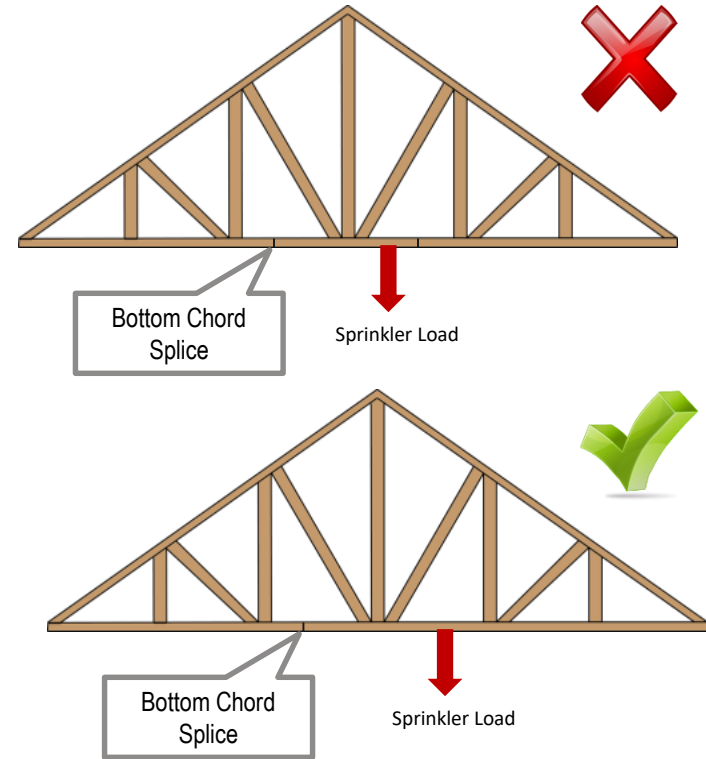

# Installation Considerations

- No more than one sprinkler system support should be attached to each truss panel.
- If this is unavoidable, special engineering is required. A Registered Design Professional should be contracted

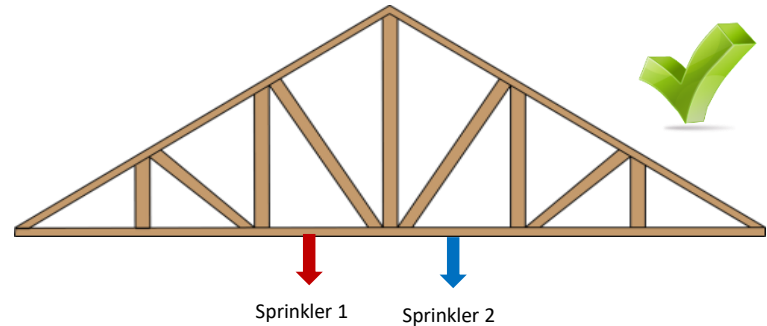
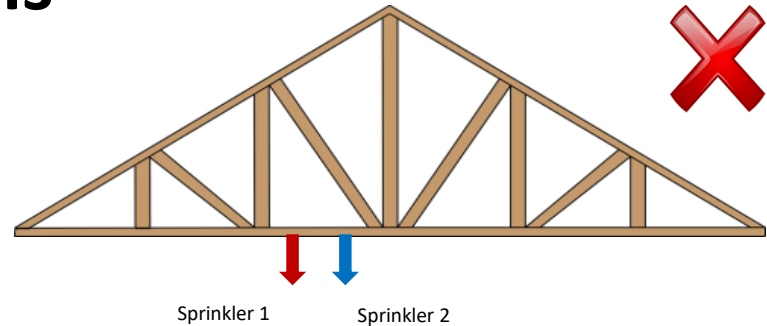

# Conclusion

- Designing trusses with sprinkler loads is a fairly straightforward process
- It is up to the Building Designer to specify sprinkler load values and to communicate those values to the Truss Designer.
- Trusses allow designers flexibility when sprinklers are required: to run pipes through open webbing, or cost effective strength upgrades to accommodate concentrated loads.



# References

- *ANSI/AWC National Design Specification (NDS) for Wood Construction*; American Wood Council; 2015.
- *ANSI/TPI 1 – National Design Standard for Metal Plate Connected Wood Truss Construction*; Truss Plate Institute; 2007.
- *ASCE/SEI 7 – Minimum Design Loads for Buildings and Other Structures*; American Society of Civil Engineers and the Structural Engineering Institute; 2010.
- *International Building Code*; International Code Council; 2015.
- *International Residential Code*; International Code Council; 2015.
- *NFPA 13 – Standard for the Installation of Sprinkler Systems*; National Fire Protection Association; 2010 and 2013.
- *NFPA 13R – Standard for the Installation of Sprinkler Systems in Residential Occupancies Up to and Including Four Stories in Height*; National Fire Protection Association; 2010 and 2013.
- *NFPA 13D – Standard for the Installation of Sprinkler Systems in One- and Two-Family Dwellings and Manufactured Homes*; National Fire Protection Association; 2010 and 2013.